

User Manual
Digital wireless DVR camera kit



Videsur New Wireless Digital Camera Kit

Content

Foreword-----	1
Statement-----	2
Liability Limit-----	3
Operating Restrictions-----	3
FCC Information-----	3
Important Information-----	4
Symbol Description-----	4
Illustration-----	5
Accessories-----	10
Parameter-----	11
Camera	
Features-----	12
Structure-----	12
Size-----	12
Receiver	
Features-----	13
Structure-----	13
Function Key-----	13
Size-----	13
Quick start-----	14
Interface-----	16
Functional menu	
System setting-----	18
Time Setting-----	19
Video System-----	19
Scan Setting-----	20
Format-----	20
Default Setup-----	21
Version-----	21
Recorder Setting	
Video Setting-----	22
Trigger Record Time-----	23
Schedule Record-----	23
Time Stamp-----	24
Overwrite-----	24
Video Record-----	25
Pair-----	25
Playback-----	26
FAQ-----	28
Certificate-----	29

Foreword

Congratulations on buying our wireless home DVR camera series. The series of products are suitable for the custody of children and elders, monitoring of residence, office, store, factory and so on. It meets FCC,CE Authentication standards, and can offer you a safe, long-lasting, reliable and high-performance service.

Our digital 2.4GHz wireless camera series work at ISM band.

It may cause interference working with other wireless equipments. Please turn off the said equipments to eliminate the interference.

Our digital 2.4GHz wireless camera series will emit electromagnetic wave, just like other wireless products. But the output power of our products is less than mobile phones.

The digital 2.4GHz wireless camera series meet wireless frequency security standards and indexes .The standards and indexes are certificated by academic organization and represent the cogitative research of the scientific organization and represent the cogitative research of the scientific workers who continuously explore and annotate the involved fields. So our products are safe for you.

Statement

1. Please read the manual in detail before using the product. The manual will present lots of significant information and notes of using the product. Please keep it well for future convenience, We hope we have satisfied your requirements, and hope it can serve you effectively and for a long time.
2. Under any circumstance, no matter civil infringement, contract or other reasons, we should not be responsible for any accidents, indirect or special damages caused by the manual or other information.
3. The guidance and description in the manual are precise for digital 2.4GHz series products at the moment when it is printed.

Liability Limit

- I We will not be responsible for any sudden occurrences caused by earthquake, theunderbolt, fire, or any third party behaviours that exceed the duties and capabilities; including customer's intentional or unintentional mistakes, misuses and uses under improper conditions.
- I We will not be responsible for any occasional loss (loss of commercial profit and business interruption), which are caused by incapability of using the product.
- I We will not be responsible for any loss or damage due to the nonperformance of the descriptions in the manual.
- I We will not be responsible for any loss or damage caused by using any third party's product.

Operating Restrictions

- I **DO NOT** put the product too close to medical equipments.

1. Radio waves might potentially cause breakdown of medical electrical equipments and thus cause incidents.
2. Place the product at least 22cm from the heart pacemaker. Radio wave potentially influences heart pacemaker and thus leads to respiratory disturbance.

I DO NOT use the product to monitor equipments or activities that are relevant to people's privacy.

1. Monitoring of equipments or activities concerned directly to people's privacy.
2. Monitoring related to people's antiques or rare articles. For it is not designed and manufactured for these purposes.

I DO NOT use the product to carry out any illegal activities (such as sneak preview, etc.)

FCC Information

NOTE: This equipment has been tested and found to comply with the limits for a Class B digital device, pursuant to part 15 of the FCC Rules, These limits are designed to provide reasonable protection against harmful interference in a residential installation.

This equipment generates, uses and can radiate radio frequency energy and, if not installed and used in accordance with the instructions, may cause harmful interference to radio communications. However, there is no guarantee that interference will not occur in a particular installation. If this equipment does cause harmful interference to radio or television reception. Which can be determined by turning the equipment off and on. The user is encouraged to try to correct the interference by one or more of the following measures:

- Reorient or relocate the receiving antenna.
- Increase the separation between the equipment and receiver.
- Connect the equipment into an outlet on a circuit different from that to which the receiver is connected.
- Consult the dealer or an experienced radio/TV technician for help.

Important Information

The user manual provides important information for customers to use the product properly, and avoid possible hurts or damages.

And this information can also decrease the hurt or damage to the lowest level.

Before you read the text. Please make sure you have completely understood the following information and symbols. Please refer to the manual while using the product.

Symbol Description



Means that if not operated to the manual, it might cause death or serious damages



Means that if not avoided timely, slight wounding or property loss might occur



Messages you need to pay attention to



Messages you should know



Means that you should not do

Illustration

DO NOT put the plastic package bags in reach of children or babies.

It might cause asphyxia of children or babies put the bags into their mouths.



DO NOT plug the AC adapter into the outlet in improper situations.

Plugging or plugging AC adapter by wet hand might cause electric shock.

Plugging AC adapter unsteadily might cause fire or electric shock.



DO NOT cover the AC adapter when it is connected to power socket, place the adapter near heaters, or put it on the floor which is equipped with a heater.

The above mentioned operation might cause fire or incidents.



DO NOT use it aboard, please abide by the airway's provision.

It might influence communication aboard and the flying apparatus if departing from the airway's regulation. This will result in accident, possible death and severe physical hurt.



DO NOT put the camera in wet places where water might splash or where rainwater and mist might erode (Except weather-proof series).

I It might cause fire, shock, short circuit ,etc.

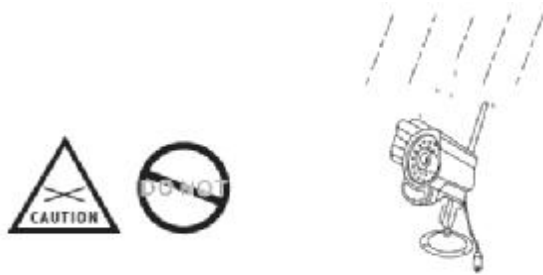

DO NOT disassemble or repair the camera, receiver or other relevant peripheral equipments by yourselves.

I Improper disassembly might cause damages to the product or the peripheral equipment.

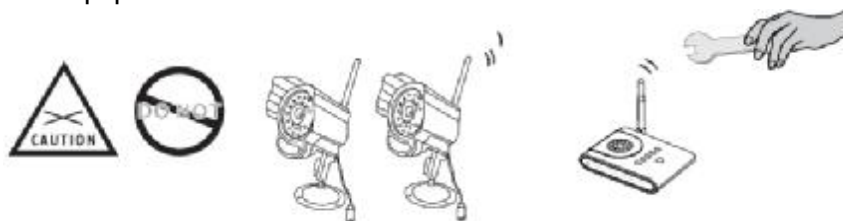

DO NOT put the camera in quaky paces.

I The camera may be unstable or out of operation if installed improperly. Such installation may also cause breakdown.

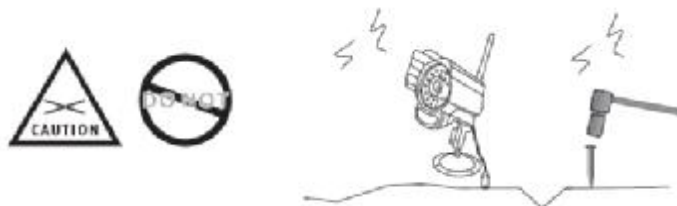

DO NOT use the receiver on the surface of thermolabile material.

I Please embed thermal insulating material when using on the surface of the thermolabile material.



DO NOT place or use the AC adapter on temperature sensitive materials.

- I The above practice might cause the plastic distortion, fading or sticking on the surface.

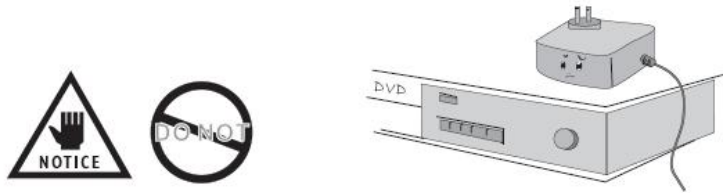

DO NOT touch, shake or hold the antenna.

- I Touching, shaking or holding the antenna might influence the receiving of electromagnetic wave, and thereby influence the receiving effect.

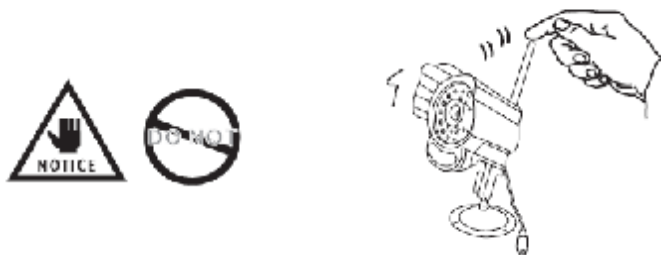

DO NOT use the camera in complex environment, The obstruction of stumbling block will affect the electromagnetic wave and influence the receiving range.

- I Wall, tree and other stumbling block might absorb, reflect the electromagnetic wave, and influence the receiving range.

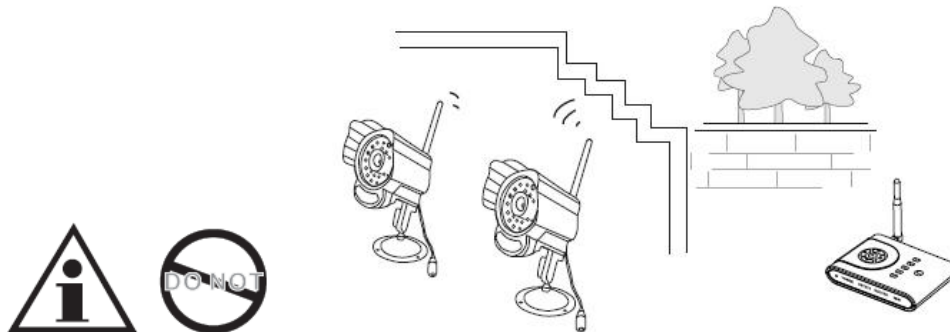

DO NOT use the camera in the places which are covered with metal.

- I The around metal, such as elevator and cabin, might shield the electromagnetic wave, and result in inability to receive signals.

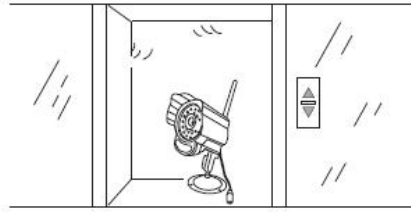

Accessories



Receiver*1



Camera*1



Antenna*2



Adapter*2



AV cable*1



Bracket*1

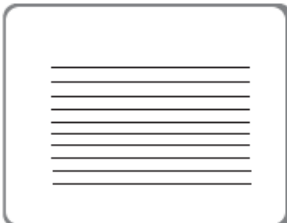

User Manual

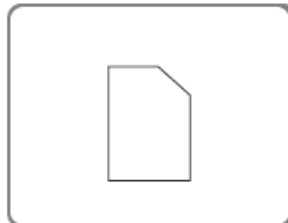

SD Card*1(optional)



Screws*3

Parameter

General	Frequency	ISM 2400—2483.5MHz
	Modulation	GFSK
	Antenna	Omni 3dBi
	Transmission distance	100m
	Operating temperature	-10°C - 60°C
	Operating humidity	20% - 80%
Receiver	Rx sensitivity	-81dBm(Typical)
	Video resolution	640*480(VGA),320*240(QVGA),ZOOM
	Video signal output	NTSC/PAL Composite, 1V pk-pk, 75ohm(with audio)
	Image input channel	4 wireless channels
	Video mode	M-JPEG AVI
	Video frame rate	9-25fps
	Photo format	JPEG
	Memory extension supported	Up to 32GB SD card
	Power supply	AC 100-240V DV 12V 500 mA
	Power consume	Max 160 mA
	Dimensions	120*84*23MM
	Net Weight	190g(including adapter)
	Record overwrite	Optional
	Recording mode	Video recording and photo shooting
	Detection sensitivity	Max 5 meters
	Record time display	Available
	Video system	NTSC/PAL adjustable
	Startup mode of recording video	Motion detection, scheduled and manual video recording
	Video file size	Approx. 10M/min
	Playback	Normal, fast forward, fast backward, pause
Camera	Sensor	CMOS1/4"
	Resolution	640*480 pixels
	View angle	66°
	Ingress protection	IP33
	Night vision Range	15 meters
	Transmit output power	100 mW
	Power supply	AC 100-240V DV12V 500 mA
	Power consume	Max 270 mA
	Dimensions	110*75*82mm
	Net Weight	555g(including adapter)

Camera

Features



- | Night Vision
- | Weather-proof
- | 1/4" CMOS
- | Minimum Illumination:0 Lux
- | 24 Infrared LEDs
- | Night Vision Range:15m



Structure

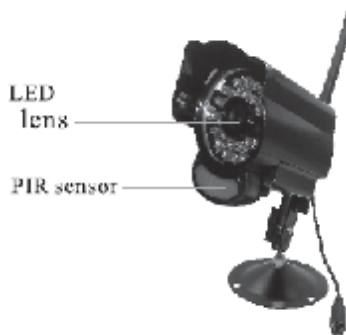
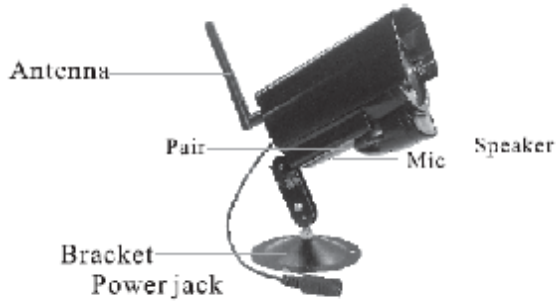

Size



Receiver

Features



- | Motion detection, scheduled and manual video recording
- | Time stamp
- | Video frame rate 9-25fps
- | Frequency :ISM 2400-2483.5MHz digital
- | Rx sensitivity: -81dBm (Typical)
- | 4 Channels loop
- | Record overwrite



Structure

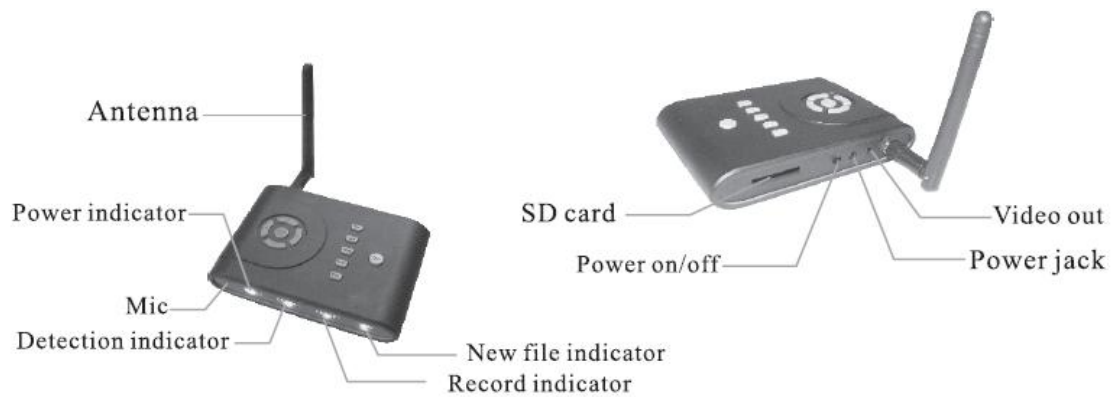

Function Key

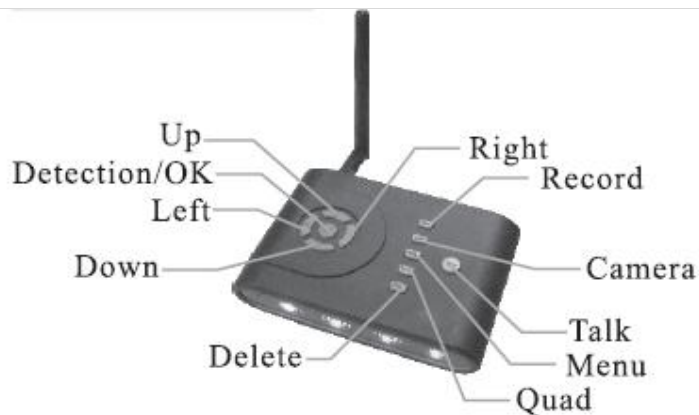

Size



Quick start

- 1、 Fix the camera in the desired position and connect it to the power supply.

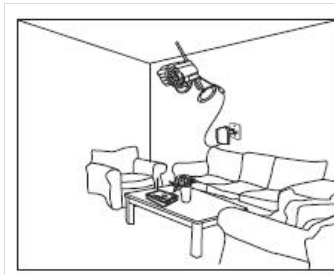

- 2、 Insert SD card into the receiver, then connect the “AV out” to TV with the AV cable supplied.



- 3、 After the receiver is connected to power supply, turn on the TV and switch it to AV mode. Now, you can see the image on the screen.
- 4、 Press “Talk” button to go to the intercom mode. Press and hold it, your sound will transmit from the receiver to the camera end; release it, you can hear the sound from the camera end.



- 5、 In real-time monitoring mode with multiple cameras, press “Cam select” button to manually switch cameras, or press “QUAD” to go to the split screen to view multiple cameras simultaneously.
- 6、 Press “OK” button, the product will go to the MD mode and the image will display an



“” symbol. If passing people were detected, the receiver will automatically record and save the video to the SD card. Press “OK” button again to exit the MD mode, then the “Detection” indicator goes out.

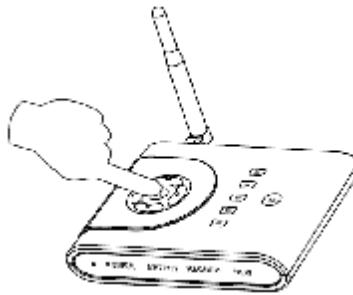

Tip:

In detection mode, if there are newly recorded video files, the “NEW” indicator of the receiver will light up. The following three methods will make this LED go out. Otherwise, it lights continuously.

- (1) Press “Menu” button to select the video to view, and then go to the menu where the video file is stored to play the video, now the LED goes out.
- (2) Press “DELETE” button, and the LED will go out. (This does not apply to the menu where the recorded video file is stored. In this menu, the “DELETE” button is still used to delete video files.)
- (3) Plug out the SD card, and the LED will go out.



“NEW” indicator



Interface

Single-camera working interface

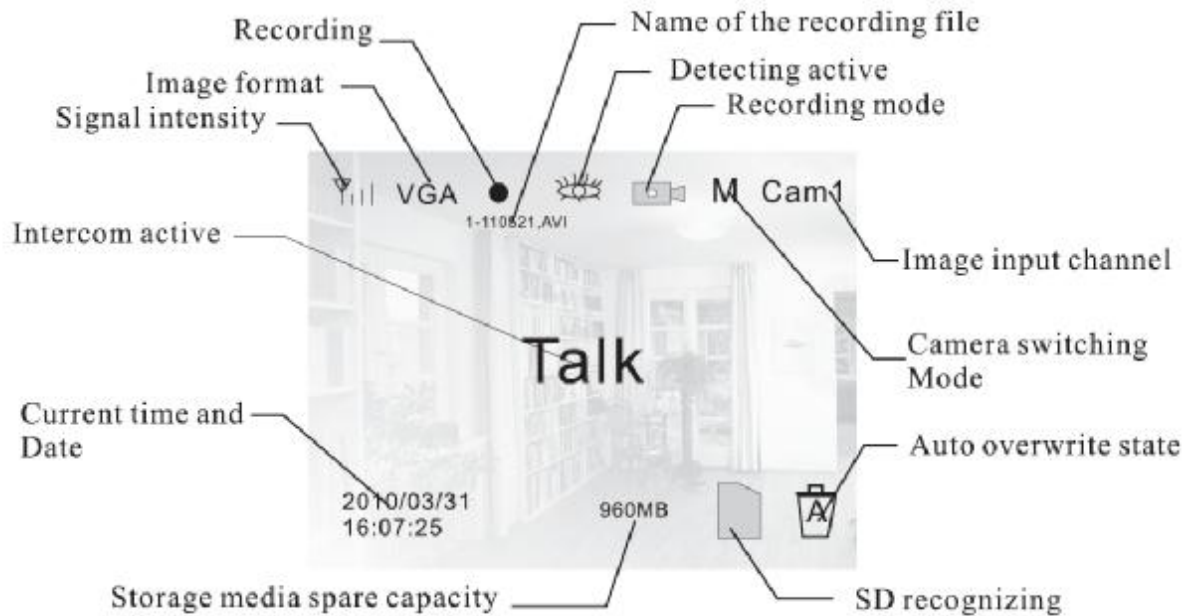

Tips:

- 1) When the storage media is normal and available for recording, the above SD card icon will appear on the screen.
When the storage media runs out of space, the SD card icon and the "Record" indicator on the screen will flash.
When the storage media is not inserted or identified, the screen will not display SD card icon and available recording time.
- 2) When you press "Talk" button, the screen will display the word "Talk", indicating that intercom function is enabled.
- 3) Interface icons of the monitor and the file name below the interface are only displayed during

recording, e.g.  **•REC**
1-005151.AVI.

- 4) The recording mode includes a shooting mode and a record mode.
- 5) When the camera is switched to the letter M, it refers to manual loop; when switched to the letter A, it refers to automatic loop.
- 6) When no signal is received, black screen will occur. Signal strength icon only displays the left part with the middle part of the screen displaying "NO SIGNAL".
- 7) When the screen is split into four parts, the top left corner of each image displays the camera number, such as CAM1, CAM2. Those split screens without images will go black.



Functional menu

Press "MENU" button to go to the following interface menu, and press "UP", "DOWN", "RIGHT" and "LEFT" button to select the setting item. The selected icon will turn blue and descriptive text of the corresponding function will appear on the top of the screen, then press "OK" button to go to the sub menu. Press the "MENU" button again to exit the interface setting menu.

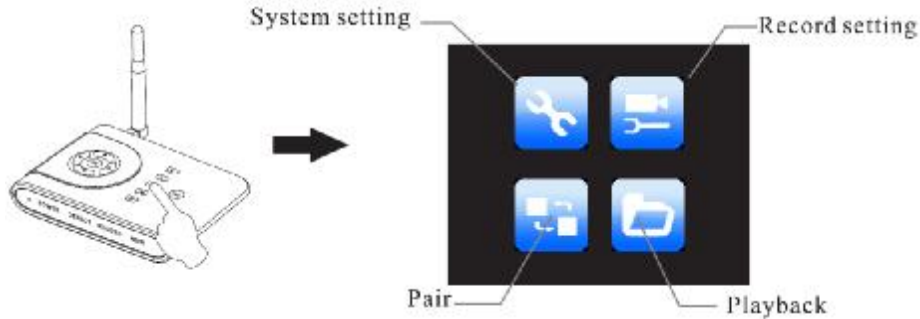

System Setting

Press "UP", "DOWN", "RIGHT" and "LEFT" button to select the setting item, the selected icon will turn blue and descriptive text of the corresponding function will appear on the top of the screen, then press "OK" button to go to related settings.

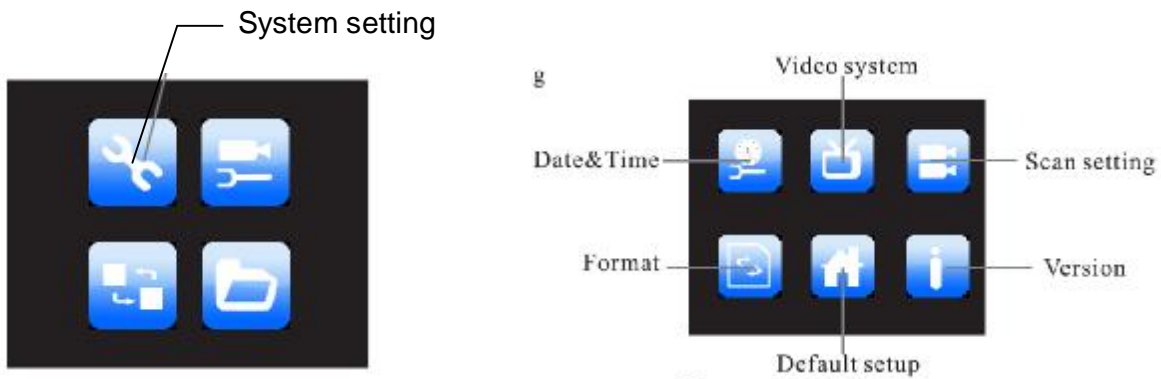

A, Time Setting

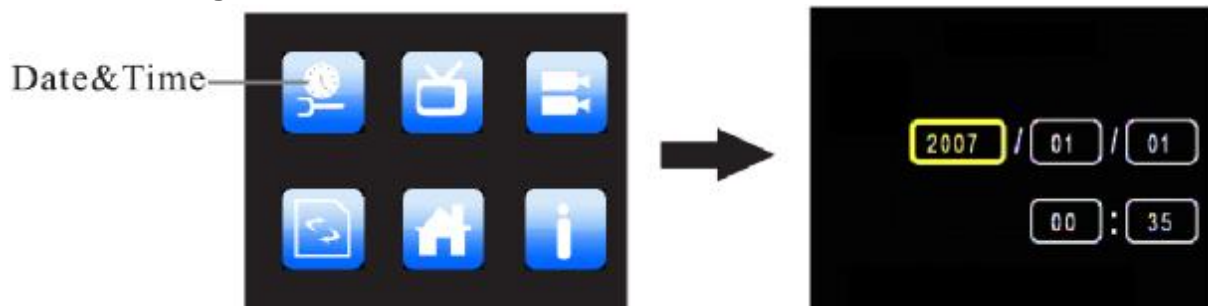

Press "RIGHT" and "LEFT" button to make selection, and then press "UP" and "DOWN" button to set. Press "OK" button to save the setting. If no setting is desired, press "MENU" button to return to the main menu.

B, Video System

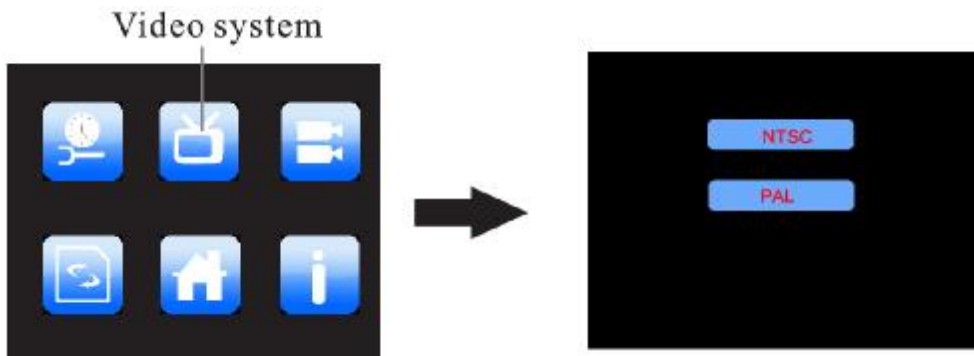

Press “UP” and “DOWN” button to select the desired system, and then press “OK” button to save the setting and exit; if no selection is made, press “MENU” button to exit.

C, Scan Setting

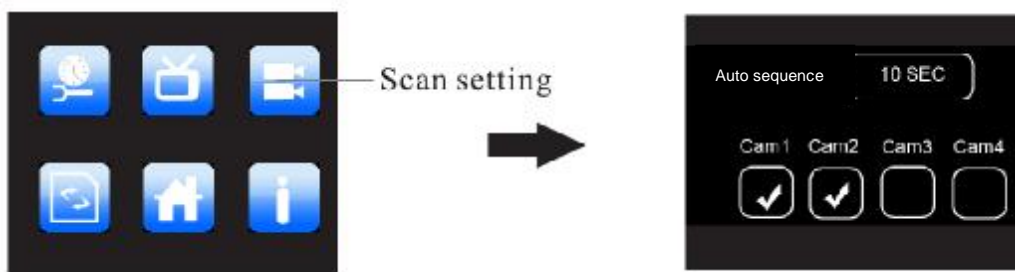

1) Select Scan Time

Press “UP” and “DOWN” button to select time. Available options include OFF, 5 sec, 10 sec and 30 sec.

2) Select Cameras

Press “LEFT” and “RIGHT” button until the desired channel turns yellow, and then press “UP” and “DOWN” button to set whether to select the corresponding channel.

When selection is done, press “OK” button to save the setting, if no setting is desired, press “MENU” button to return to the main menu.

D, Format

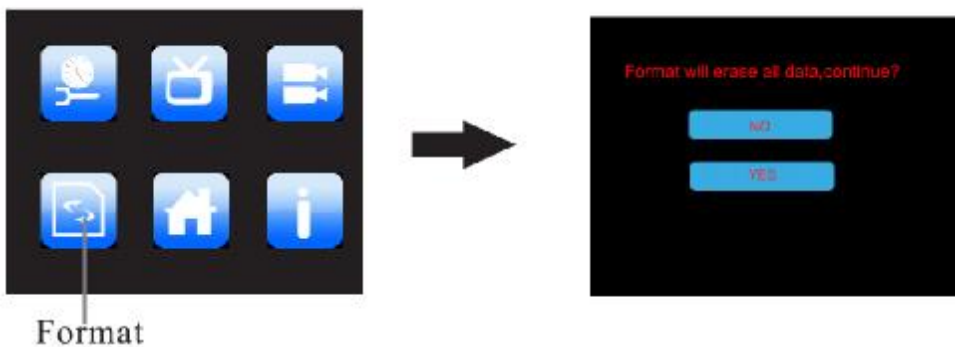

Press “UP” and “DOWN” button to select “YES / NO”, the selected option turns blue. Press “OK” button to save the setting and exit; if no selection is made, press “MENU” button to exit.

E, Default Setup

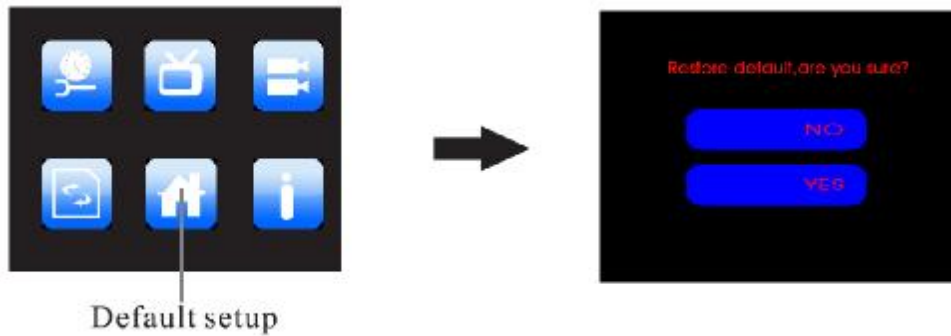

Press "UP" and "DOWN" button to select "YES / NO", the selected option turns blue. Press "OK" button to save the setting and exit; if no selection is made, press "MENU" button to exit.

F, Version

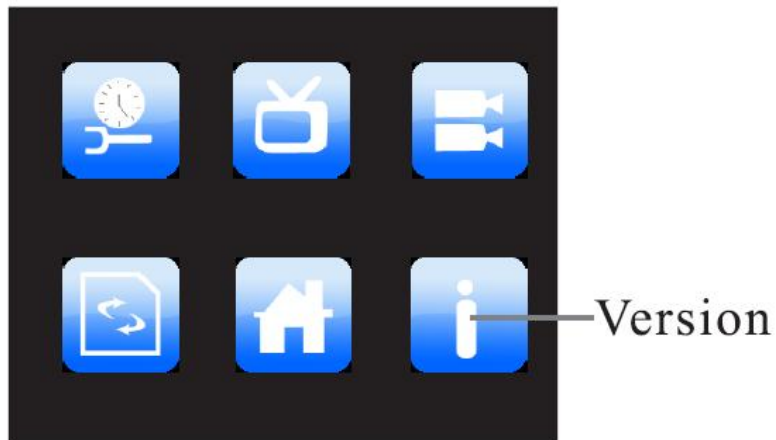

Enable this function to display the version of the receiver and the camera.

Recorder Setting

Press UP, DOWN, RIGHT and LEFT to select the item to set, the selected icon will turn blue and descriptive text of the corresponding function will appear on the top of the screen, then press "OK" button to go to the related settings.

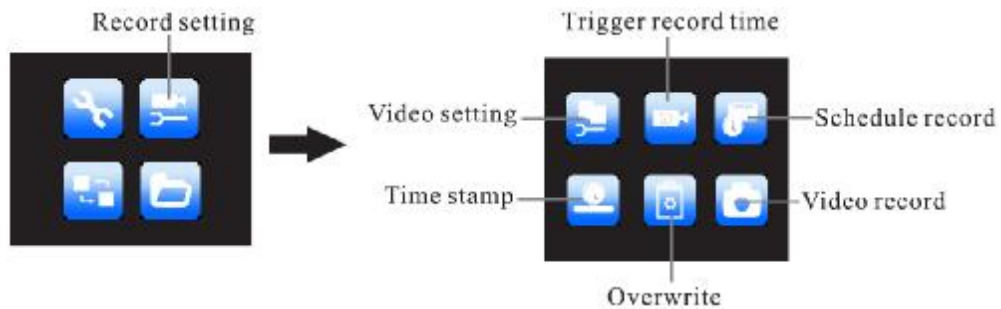

A, Video Setting

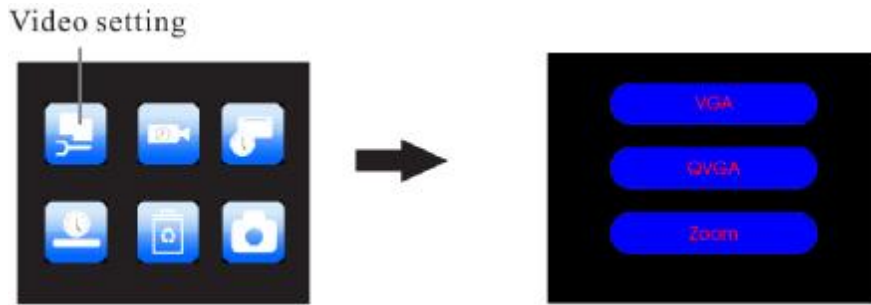

Press “UP” and “DOWN” button to make selection, the selected option turns blue. Press “OK” button to save the setting and exit; if no selection is made, press “MENU” button to return to the previous menu.

B, Trigger Record Time

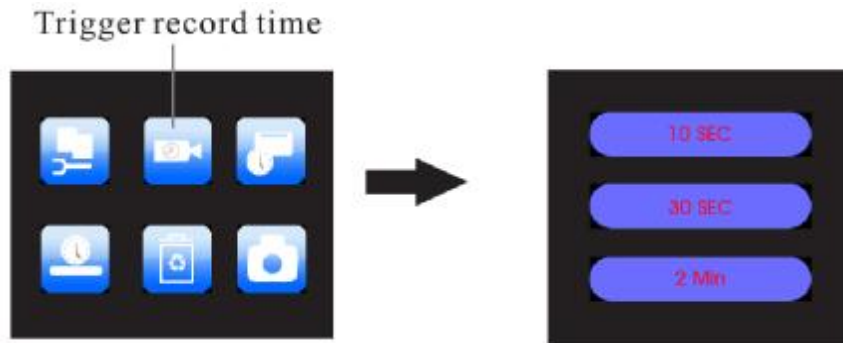

Press “UP” and “DOWN” button to select the detection record time, the selected option turns blue. Press “OK” button to save the setting. The record time can be set to be 10SEC, 30SEC and 2 min. If no setup is desired, press “MENU” button to return to the previous menu.

C, Schedule Record

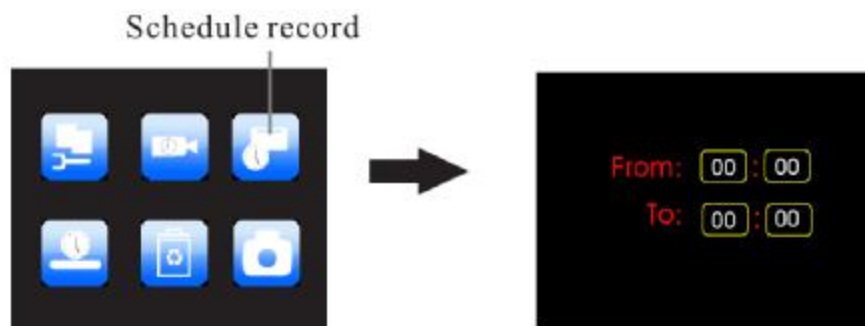

Press “RIGHT” and “LEFT” button to make selection, and then press “UP” and “DOWN” button to set time.

When selection is properly done, press “OK” button to save the setting, if no setting is desired, press “MENU” button to return to the main menu.

D, Time Stamp

When the "TIME STAMP" is enabled, the system will display the record date and time on the recorded video.



Press "UP" and "DOWN" button to select whether to enable, when the selection is done, press "OK" button to save the setting. If no selection is made, press "MENU" button to return to the main menu.

E, Overwrite

When the "Overwrite" function is enabled, the device will delete the oldest video files recorded to free space for storing new videos after the storage media is full. If "Record Overwrite" is disabled, the device will stop recording when the storage media is full.

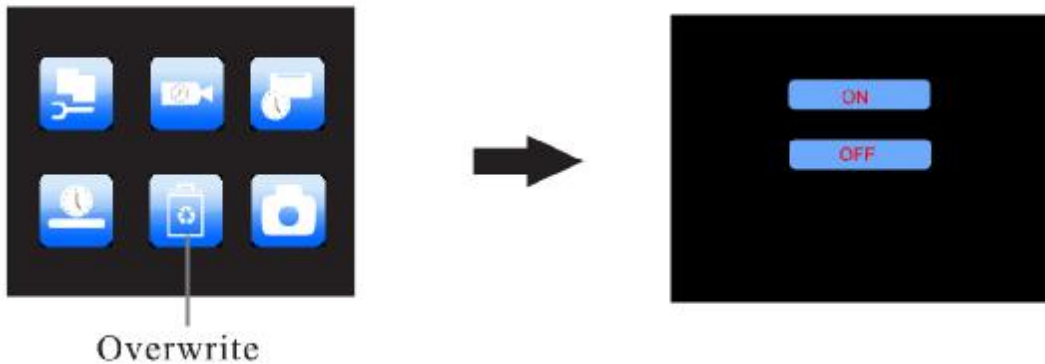

Press "UP" and "DOWN" button to make selection, when the selection is properly done, press "OK" button to save the setting, if no setting is desired, press "MENU" button to return to the main menu.

F, Video Record

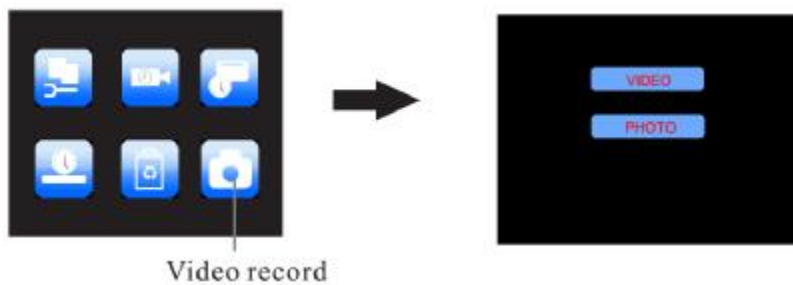

Press "UP" and "DOWN" button to make selection, when the selection is properly done, press "OK" button to save the setting, if no setting is desired, press "MENU" button to return to the main menu.

Tip:

A: In recording mode, “. Record” indicator lights up when recording starts, and “REC” icon will appear on the monitor screen; the “Record” indicator goes out when recording stops.

B: In shooting mode, “Record” indicator flashes when shooting starts, and “-----” icon will appear on the monitor screen; the “Record” indicator goes out when recording stops.



Pair

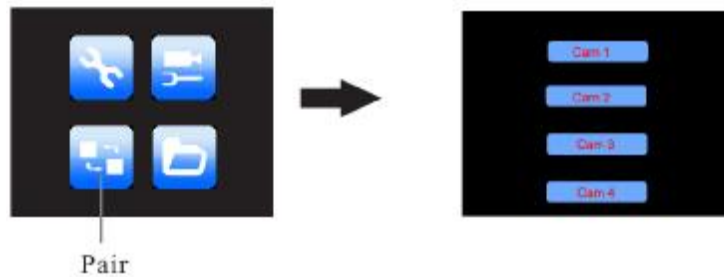

Press “UP” and “DOWN” button to select the desired camera number, when the selection is done, press “OK” button to enable pairing.

When pairing is enabled, the screen will go black, indicating “**Please press pair key on camera side**”. When pairing is successfully done, the camera image will be displayed. Pair other cameras in the above way, when finished, Press “MENU” button to exit the menu and display images.

Playback

After entering the playback mode, the user is required to select the data folder where the file to play is stored. The root directories are “Video” and “Picture”.

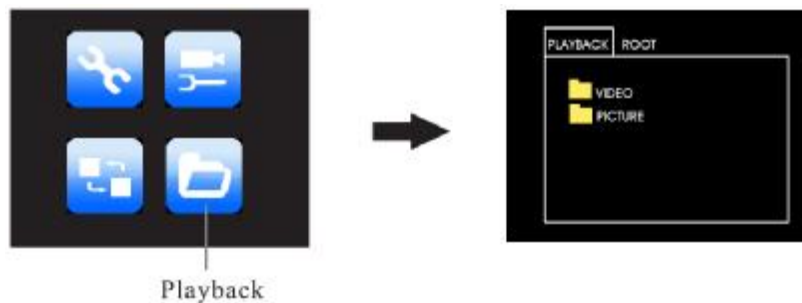

The name of the subdirectory is named based on the recording date. Press “UP” and “DOWN” button to select the file time. After selecting the right one, press “OK” button to enter the folder.

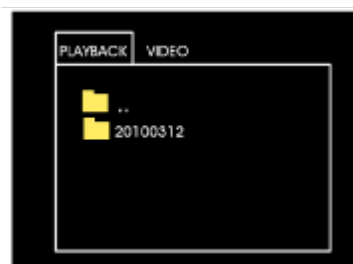

NOTE: the first file icon in the subdirectory indicates that you can return to the previous directory.



After entering the folder, select the file to play.

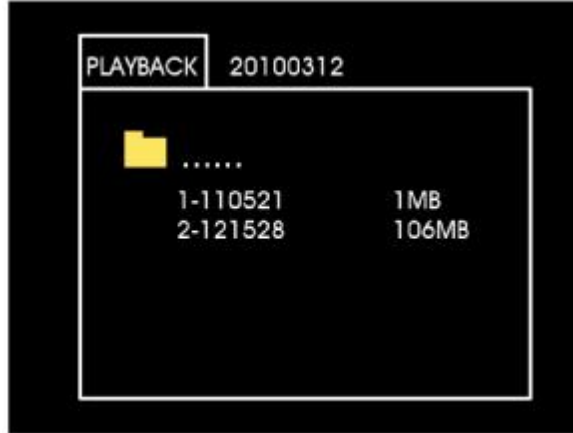



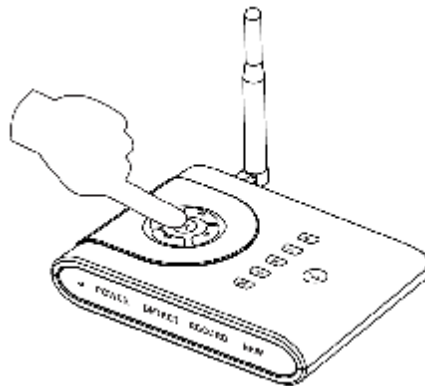

Press “OK” button to play. The file name is named based on the recording camera and time “CAM#-HHMMSS” e.g. 1-110521.
In the course of play, press “Left” button for fast backward and “Right” button for fast forward.
Press “OK” button to pause and press it again to continue.

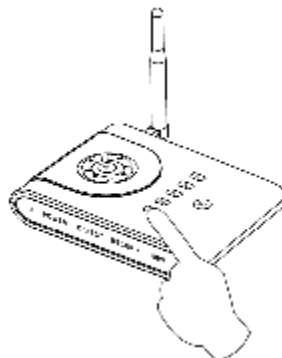

After selecting files or folders, press “DELETE” button to pop up options to delete, and then press “LEFT” and “RIGHT” button to select “YES” or “NO” to decide whether to delete or not to delete the file. Press “Menu” button to return to the previous menu.

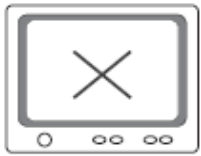

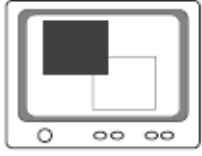
FAQ

Abnormal Phenomena		Possible Reasons/Solutions
 No image	 No sound	Check whether camera/receiver connected to power supplies and power on. Make sure that the A/V cable is connected correctly.
 No color	 Normal sound	Mismatching system of TV(monitor) and cameras, TV may not support NTSC video format.

Certificate

The product is meet with CE/FCC/ROHS. Please see the certificates as following:





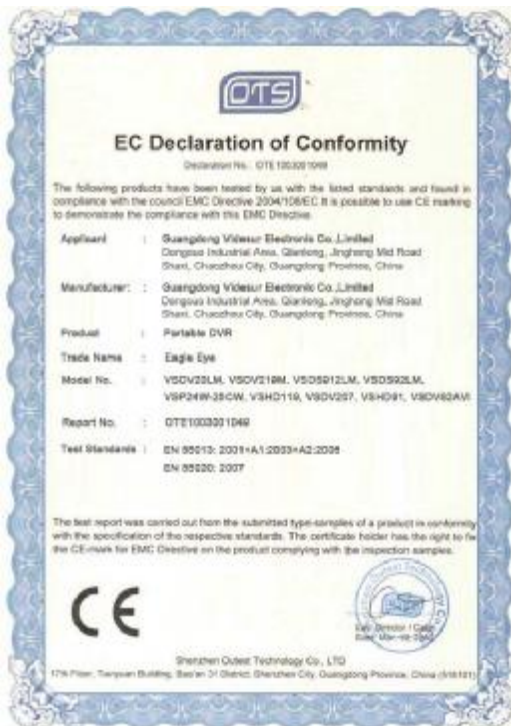

*Improve the Quality
of Your Life*